

# LIST OF CONTENTS

Decryptor Ultegra 884 - Patent pending

**KEYLINE**  
PASSION FOR KEY INNOVATION



<b>1</b>	<b>General Information</b>	<b>3</b>
1.0.1	Scope and contents of the manual	3
1.0.2	How to store the manual	3
1.0.3	Graphic symbols	3
1.1.0	Manufacturer's identification data	4
1.2.0	Working conditions	5
1.2.1	Intended use	5
1.2.2	Improper Use	5
1.2.3	Limitations of use	5
1.3.0	Terms and Conditions of Technical Assistance	6
1.3.1	Technical service and maintenance	6
1.3.2	Manufacturer's address	6
<b>2</b>	<b>Safety instructions</b>	<b>7</b>
2.1.0	Safety legislation	7
2.1.1	General safety requirements	7
2.2.0	Residual risks	8
<b>3</b>	<b>Ultegra 884 Decryptor description</b>	<b>9</b>
3.1.0	Main features	9
3.1.1	Components of the cloning tool	10
3.2.0	Accessories supplied with the cloning tool	11
3.3.0	Electric circuit	11
3.4.0	Technical features	12
<b>4</b>	<b>Packing, transport and installation</b>	<b>13</b>
4.1.0	Packing	13
4.2.0	Transport	13
4.2.1	Unloading and handling	13
4.2.2	Item ckecklist and detection of damage	14
4.3.0	Placing the cloning tool	14
4.3.1	Temporary storage	14
<b>5</b>	<b>Installation</b>	<b>15</b>
5.1.0	General Instructions	15
5.1.1	Work station	15
5.2.0	Environmental conditions	15
5.2.1	Temperature and humidity	15
5.2.2	Working environment	15
5.2.3	Lighting	15
5.2.4	Vibrations	16
5.3.0	Connections	16
5.3.1	Grounding	16
<b>6</b>	<b>Use</b>	<b>17</b>
6.1.0	Instructions for the operator	17
6.1.1	General instructions for use	17
6.1.2	Preliminary check-list and start-up	17
6.2.0	Settings	17
6.2.1	Getting started	17

6.3.0	How to use the cloning tool	18
6.3.1	Display	18
6.3.2	Starting the cloning tool	18
6.3.3	Software Version	18
6.3.4	Transponder reading (on the original key / remote control)	19
6.4.0	Cloning the fixed code transponder	22
6.5.0	Cloning of keys with Texas* Crypto 1, 2 and 3 transponder (using the KeyLine TK40 electronic head)	23
6.6.0	Cloning of transponder keys / remote controls with PHILIPS® Crypto PH20 transponder (using TK60)	26
6.7.0	Cancellation, in order to use TK60 again	30
6.8.0	Language setting	31
6.9.0	Error messages	32
6.9.1	Error messages during reading	32
6.9.2	Error messages during writing	32
6.10.0	Transponder identification	32
6.11.0	Updating the software	34
<b>7</b>	<b>Maintenance</b>	<b>35</b>
7.1.0	General information	35
7.1.1	Skills of maintenace personnel	35
<b>8</b>	<b>Dismantling and disposal</b>	<b>36</b>
8.0.1	Waste disposal	36
8.0.2	Disposal of the packing material	36
8.1.0	The WEEE directive	36



The user's and maintenance manual of the cloning tool "**Ultegra 884 Decryptor**", for the duplication and identification of transponder car keys, (henceforth "cloning tool") contains all operation instructions on how to use the cloning tool at best while guaranteeing the safety of operators.

## 1.0.1 SCOPE AND CONTENTS OF THE MANUAL

This manual provides basic information on the installation, operation and maintenance of the cloning tool.

It is addressed to machine operators and it enables them to use the cloning tool effectively, even if they do not have any previous specific knowledge. This manual describes the characteristics of the cloning tool at the time it is originally manufactured; therefore it may not capture later technological improvements introduced by **KEYLINE S.p.A.** as part of its constant endeavour to enhance the performance, ergonomics, safety and functionality of its products.

**KEYLINE S.p.A.**, reserves the right not to update the manuals of previous versions of the machine.

Users must follow the instructions contained in this manual scrupulously, especially those concerning safety norms and ordinary maintenance.

## 1.0.2 HOW TO STORE THE MANUAL

The manual must always accompany the cloning tool that it refers to. The manual must be stored in a safe place, away from dust and moisture and it must be accessible to all users who shall consult it any time they are in doubt on how to operate the cloning tool.

**KEYLINE S.p.A.** reserves the right to modify its production and related manuals without necessarily updating previous versions of the reference materials.

The customer shall store any updated copies of the manual -or parts of it - delivered by the manufacturer as an attachment to this manual.

For any further information regarding this manual or the use and maintenance of the machines please contact **KEYLINE S.p.A.**

## 1.0.3 GRAPHIC SYMBOLS



- Indicates operations that can be either dangerous for people and/or disrupt the correct functioning of the machine.



- Indicates prohibited operations.

1.1.0 MANUFACTURER'S IDENTIFICATION DATA

KEYLINE S.p.A.  
 Via Camillo Bianchi, 2  
 31015 Conegliano (TV) - ITALY  
 Tel.: +39.0438.202511  
 Fax: +39.0438.202520  
 Web: www.keyline.it  
 E-mail: info@bianchi1770.it  
 Technical Support: decryptor@bianchi1770.it

Key duplicating machine "**Ultegra 884 Decryptor**"  
 voltage: \*  
 absorbed power: \*  
 absorbed current: \*  
 \* See "Technical features" page 12.



		Via Camillo Bianchi, 2 31015 Conegliano (TV) -IT Tel +39.0438.202511 Fax +39.0438.202520 www.keyline.it info@bianchi1770.it decryptor@bianchi1770.it	
		BIANCHI1770SPA Company by	
Tipo Type	<input type="text"/>		
Matricola Serial No.	<input type="text"/>		
VOLT	Hz	Kw	RPM
<input type="text"/>	<input type="text"/>	<input type="text"/>	<input type="text"/>



Figure 1: Location of the machine data plate



## 1.2.0 WORKING CONDITIONS

### 1.2.1 INTENDED USE

The cloning tool described in this manual has been designed to identify, read and duplicate car keys with fixed code transponders and Crypto transponder codes Texas\* and Philips\* PH20 in "Stand Alone" mode, and identify all types of crypto transponder codes.

Moreover, the Decryptor Ultegra 884 can identify and clone Philips\* Crypto PH20 remote controls for vehicles. With regard to this product, the manufacturer reserves the right to issue dedicated information and instructions after 15th October 2010, when the RK60 type KeyLine remote control will be released.

### 1.2.2 IMPROPER USE

The improper use of the cloning tool includes using the cloning tool to obtain different production than the one described in this manual. Should this occur the manufacturer shall take no responsibility for damage to materials or persons and shall consider all warranties on the cloning tool void.

### 1.2.3 LIMITATIONS OF USE

The Ultegra 884 Decryptor can be used exclusively to clone transponder car keys or electronic heads produced by KEYLINE.

Decryptor Ultegra 884 - Patent pending

**KEYLINE**  
PASSION FOR KEY INNOVATION



\*TEXAS is a broad meaning of TEXAS Instruments Incorporated registered as a trademark  
\*PHILIPS is a broad meaning of PHILIPS Instruments Incorporated registered as a trademark

### 1.3.0 TERMS AND CONDITIONS OF TECHNICAL ASSISTANCE

#### 1.3.1 TECHNICAL SERVICE AND MAINTENANCE

The manufacturer shall be accountable for servicing the product during the warranty period and for causes related to the use of the cloning tool.

Ordinary maintenance operations shall be performed by the personnel who use the cloning tool.

Any other operation (special maintenance, repairs, replacements etc..) shall be carried out by qualified personnel or contractors. **KEYLINE S.p.A.** is available for this assistance and guidance.

**KEYLINE S.p.A.** is at your disposal for:

- clarification and advice;
- delivery of spare parts;
- direct assistance through in-house technical counsel;
- direct assistance through authorised personnel.

Any servicing by the operator itself during the warranty period must be previously authorised by **KEYLINE S.p.A.**

The warranty will become void in case of:

- unauthorised operations and use;
- use of non-original spare-parts.

#### 1.3.2 MANUFACTURER'S ADDRESS

For any further information or technical service related to extraordinary maintenance or repairs, please contact:

KEYLINE S.p.A.  
Via Camillo Bianchi, 2  
31015 Conegliano (TV) - ITALY  
Tel.: +39.0438.202511  
Fax: +39.0438.202520  
Web: [www.keyline.it](http://www.keyline.it)  
E-mail: [decryptor@bianchi1770.it](mailto:decryptor@bianchi1770.it)

To facilitate communication please state:

- the name of the final customer and of the KEYLINE distributor;
- the identification data printed on the machine data plate (fig. 1).



# SAFETY INSTRUCTIONS

Decryptor Ultegra 884 - Patent pending

**KEYLINE**  
PASSION FOR KEY INNOVATION



## 2.1.0 SAFETY LEGISLATION

The Ultegra 884 Decryptor and the relevant accident prevention equipment comply with the health and safety requirements of the Low Voltage Directive **2006/95/EEC**.

This manual lists all safety instructions that the operator must follow during the installation and functioning of the cloning tool.

Failing to respect the instructions may compromise the safety conditions envisioned during design and testing phases.

When employed for their intended use all machines marked **CE** comply with EU 'Low Voltage' directive **2006/95/EEC** and later amendments (in accordance with norm **EN 60950**).

**Warning:**



**Important!**

---

---

**Users must be informed about the instructions contained in the following pages.**

---

---

---

---

**Users must carefully follow the instructions contained in this manual.**

---

---

## 2.1.1 GENERAL SAFETY REQUIREMENTS

**Warning:**



**Important!**

---

---

**Make sure that the grounding system is well connected.**

---

---

---

---

**Do not pour water or other liquids onto electrical cables and connections.**

---

---

## 2.2.0 RESIDUAL RISKS

The cloning tool has been designed with the almost care to make it safe throughout manufacturing, quality control, transport, adjustment and maintenance operations. Nevertheless, not all risks for either operators or the environment could be eliminated, be it for technological reasons (material reliability) or management-related issues (overcomplicated operations).

Therefore, when operating the cloning tool, the following residual risks - as well as those connected with its use - must be taken into due consideration:



- **Risks related to the place of installation**

The place where the cloning tool is installed might present hazards that could disrupt its correct functioning (see paragraph 5.2.0. on page 15).



- **Electrical hazard**

Since the cloning tool is equipped with electrical devices, in case of faults there might be a risk of electrocution. The power line must be fitted with the appropriate control and protection devices (circuit breaker, thermal overload switch and differential switch).

# ULTEGRA 884 DECRYPTOR DESCRIPTION

Decryptor Ultegra 884 - Patent pending



## 3.1.0 MAIN FEATURES

**Ultegra 884 Decryptor** cloning tools have been designed and built to keep pace with the constant evolution of transponder car keys.

**Ultegra 884 Decryptor** cloning tools feature the most innovative electronic components in the field of radio frequencies thus allowing an easy detection, identification reading and cloning of fixed code transponders, crypto transponder codes Texas\* and Philips\* PH20, and the identification of all other Crypto transponder models, including some types of car transponders (see paragraph 1.2.3. on page 5).

**Ultegra 884 Decryptor** cloning tools are easy to use: instructions appear in the display in the form of simple and clear messages. The cloning tool's function menu is meant to meet all of the user's needs throughout regular key duplication/cloning procedures. The unit is also equipped with an automatic troubleshooting system that warns the user about problems.

**Ultegra 884 Decryptor** cloning tools can detect, identify, read and duplicate (through an appropriate KEYLINE key product) the following types of transponders:

TYPES OF TRANSPONDERS	IDENTIFICATION	CLONING
Fixed* code for Philips	✓	✓
Crypto* for Philips I	✓	✓ **
Crypto* for Philips II	✓	✓
Fixed* code for Megamos	✓	✓
Crypto* for Megamos	✓	-
Fixed* code for Temic	✓	✓
Crypto* for Temic	✓	-
Fixed* code for Texas	✓	✓
Crypto* for Texas 1 and 2	✓	✓
Crypto* for Texas 3	✓	✓

\*Philips, Megamos, Temic and Texas Instruments are registered trademarks

\*\*Only for the following vehicle models:

MAKE	MODEL	YEAR
Peugeot	206	1998-2001
Peugeot	206 Cabrio	2001-2002
Peugeot	406	1999-2002
Ford	Galaxy	2000-2006
Seat	Alhambra	2000-
Seat	Arosa	2001-2005
Seat	Inca	2000-2003
Volkswagen	Cabrio	2000-2005
Volkswagen	Caddy	2000-2003
Volkswagen	Golf Cabrio	2000-2004
Volkswagen	Lupo	2000-2005
Volkswagen	Polo	2000-2001
Volkswagen	Sharan	2000-
Volkswagen	Transporter	2001-2004

3.1.1 COMPONENTS OF THE CLONING TOOL



Figure 2: Components of the cloning tool

COMPONENTS OF THE CLONING TOOL			
1	ON/OFF Switch	7	Power supply connection
2	Read/write key insertion slot	8	Serial port (RS232)
3	Liquid Cristal Display	9	USB interface
4	WRITE button	10	Anti-shock body
5	READ button	11	External 9-15 Volt power supply
6	Number keyboard	12	9-15 volt power cable

**3.2.0 ACCESSORIES SUPPLIED WITH THE CLONING TOOL**

The cloning tool comes with a complete kit of standard accessories:

- External 9-15 Volt power supply unit (11)
- 9-15 volt power cable (12)
- User's manual

**3.3.0 ELECTRIC CIRCUIT**

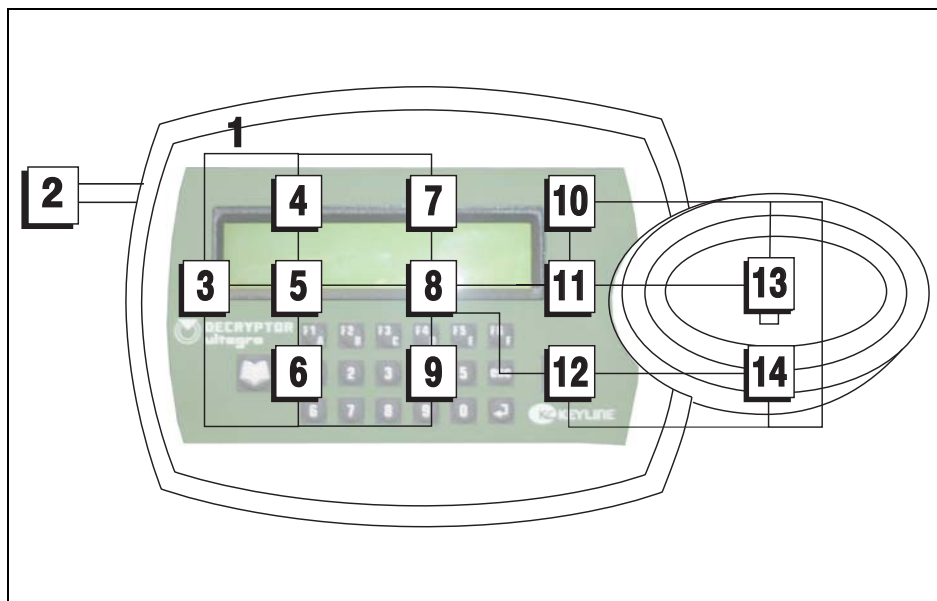

Figure 3: Electric circuit diagram

ELECTRIC CIRCUIT DIAGRAM PARTS			
1	Electronic board	8	Control unit
2	External 9-15 V DC power supply	9	Keyboard
3	Internal power supply 2	10	Internal power supply 1
4	RS232 serial interface	11	Radio module for modulation transponder
5	Communication module	12	Radio module for Texas transponder
6	USB interface	13	Antenna for transponder
7	Display	14	Antenna for Texas transponder

3.4.0 TECHNICAL FEATURES

<b>CLONING TOOL DIMENSIONS</b>	
Width	220 mm (Inch. 8,6)
Height	70 mm (Inch. 2,7)
Depth (Length)	130 mm (Inch. 5)
Weight	1 Kg (2.2 Lbs)
<b>POWER SUPPLY</b>	
External power supply	100/250 V - 50/60 Hz
Absorption	1 Ampere
Type of power supply unit	Universal
<b>TECHNOLOGY FEATURES</b>	
Field frequency of key insertion slot	125 KHz
Memory	4 GB
Interface	Serial port RS232 and USB
Working temperature	0°C ÷ + 40°C + 32 °F ÷ + 105 °F

Table 1: Technical features



# PACKING, TRANSPORT AND INSTALLATION

## 4.1.0 PACKING

Prior to transport, the cloning tool and its component parts are packed in a cardboard box and fixed in it with shaped cardboard in order to ensure a safe and damage-free handling of the goods.

The dimensions of the carton are shown below.

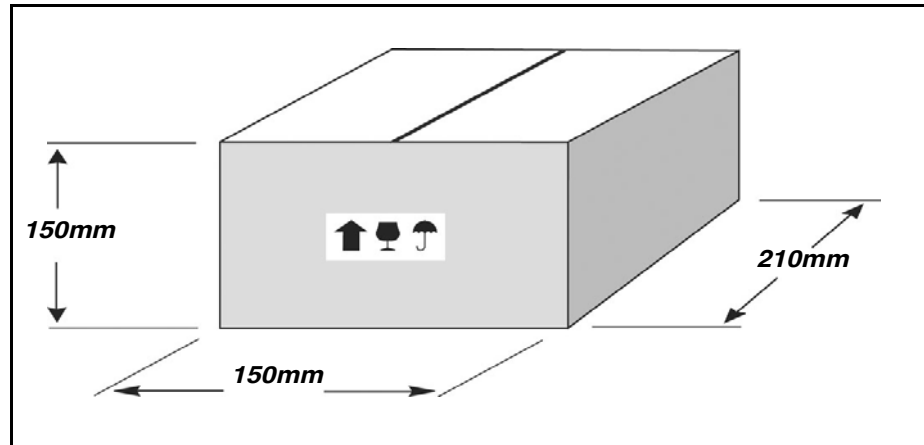

Figure 4: Package size

**Warning:**



**IMPORTANT!**

---

---

**We recommend you to keep the packaging during the warranty period.**

---

---

## 4.2.0 TRANSPORT

As a rule, the cloning tool is dispatched with component parts already assembled.

The markings on the packing materials indicate how to handle the machine during transport.

### 4.2.1 UNLOADING AND HANDLING

The machine can be unloaded manually; no hoisting equipment is required.

**Warning:**



---

---

**Avoid dropping the machine, even a small damage could impair its correct functioning.**

---

---

4.2.2 ITEM CHECKLIST AND DETECTION OF DAMAGE

Upon delivery, check that all items listed in the consignment note or in the packing list are in good condition. If any items are missing, the packing has been tampered with or the goods are damaged write a statement in the delivery note, sign it and have the carrier sign it too. Notify **KEYLINE S.p.A.** immediately and wait for the relevant instructions.

Please note that if you fail to notify us of the damage immediately you will lose your rights to damage compensation.

Do not remove protective covers before the installation - unless they are damaged.

Packages that were opened to examine the contents must be handled with care to avoid damaging the goods; re-pack the parts and store them in a safe place until the installation.

For more detailed information on how to handle these parts refer to the chapter "Temporary storage" page 14.

4.3.0 PLACING THE CLONING TOOL

Free the device from the protective padding, then place the **Ultegra 884 Decryptor** on the work bench.

4.3.1 TEMPORARY STORAGE

If the installation of the cloning tool does not occur immediately, store the machine in a dry and properly ventilated place.

Warning:



**If the period of inactivity is longer than 6 months, inspect the cloning tool carefully.**

**To avoid that inaccurate operations or re-assembling may damage the equipment at the time of start-up, the utmost care must be used in performing such inspection, that shall be carried out by qualified and skilled personnel.**

Warning:

**IMPORTANT! Make sure that:**



**the iron structures are not dripping;**

**The transit of equipment, goods or people near the cloning tool does not damage it.**



## 5.1.0 GENERAL INSTRUCTIONS

### 5.1.1 WORK STATION

The cloning tool will be operated only by one operator who will stand in front of the cloning tool and make sure of the following:

- Keep the work station tidy and free from objects that may hamper regular cloning tool operations;
- Make sure that environmental conditions allow to work safely (appropriate lighting, temperature and humidity);
- Keep unauthorised personnel out of the area.

## 5.2.0 ENVIRONMENTAL CONDITIONS

### 5.2.1 TEMPERATURE AND HUMIDITY

The cloning tool should be used in rooms with a temperature range of 0 - 40 °C (32 °F - 105 °F) and a relative humidity lower than 50 - 60%.

### 5.2.2 WORKING ENVIRONMENT

The cloning tool must be used in a place protected from bad weather (rain, hail, snow etc.).

#### Warning:



**If the cloning tool is used in places exposed to corrosion, maintenance shall be scheduled in such a way as to prevent extreme wear of the components.**



**Do not use the cloning tool in explosive or partially explosive atmosphere or in the presence of inflammable liquids of gases.**

### 5.2.3 LIGHTING

In the place of installation lighting must be appropriate, in order to allow the correct use and maintenance of the cloning tool. The user shall be responsible for complying with the legislation in force regarding lighting.

5.2.4 VIBRATIONS

The use of **Ultegra 884 Decryptor** does not cause any vibrations.

5.3.0 CONNECTIONS

5.3.1 GROUNDING

**Ultegra 884 Decryptor** have been designed in compliance with the safety legislation in force and feature appropriate safety devices to prevent work accidents.

The cloning tool must be grounded through the centralised circuit of the place of installation.

Warning:



Make sure that the main voltage is compatible with the cloning tool voltage.

Make sure that the motive power outlets are grounded.

Warning:



Do not touch the cloning tool when your hands and/or feet are wet or humid;

Avoid any contact with grounded plates.

Decryptor Ultegra 884 - Patent pending

**KEYLINE**  
PASSION FOR KEY INNOVATION



## 6.1.0 INSTRUCTIONS FOR THE OPERATOR

This section contains comprehensive instructions on how to detect, identify, read and duplicate a transponder key (or remote control).

### 6.1.1 GENERAL INSTRUCTIONS FOR USE

The following is a list of instructions that operators must follow in order to guarantee steadily efficient and safe cloning tool operations.

- The cloning tool must be kept away from electronic equipments;
- Keep the power cable away from heat, humidity, oil, water and sharp cutting items;
- Do not expose the cloning tool to bad weather;
- Disconnect the cloning tool power cable from the main outlet before any maintenance or repair operation or whenever the cloning tool remains unused for a long time;
- Use only original spare parts.

#### Warning:



---

---

**Follow safety instructions carefully.**

---

---

### 6.1.2 PRELIMINARY CHECK-LIST AND START-UP

Before starting the cloning tool the operator must:

- Check that the power cable is properly connected to the outlet.
- Check that the cloning tool is placed on a flat surface;
- Carry out a visual inspection of the cloning tool to make sure that no part has been removed or modified.
- Check that the cloning tool and the surrounding area are clean and no clothes, tools, spare parts and other objects may hamper cloning tool operations.

### 6.2.0 SETTINGS

Ultegra 884 Decryptor is delivered ready for use and does not need to be adjusted or calibrated.

### 6.2.1 GETTING STARTED

Before starting the cloning tool connect it to the main outlet (100/220V) through the power supply unit that comes with the cloning tool.

6.3.0 HOW TO USE THE CLONING TOOL

6.3.1 DISPLAY

Easy messages will explain each step and guide the user throughout the key duplicating process.

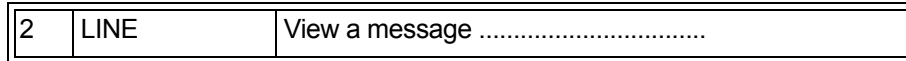
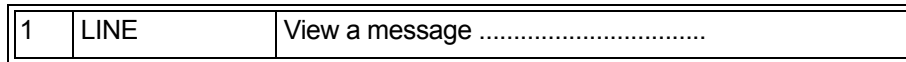
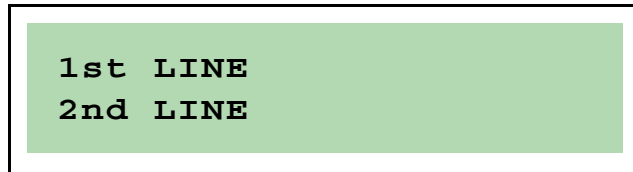

6.3.2 STARTING THE CLONING TOOL

To start the cloning tool, turn on the ON/OFF switch located in the rear of **Ultegra 884 Decryptor**.

6.3.3 SOFTWARE VERSION

When the device is turned on, the display will show, for a few seconds, the KL logo and then the following message:

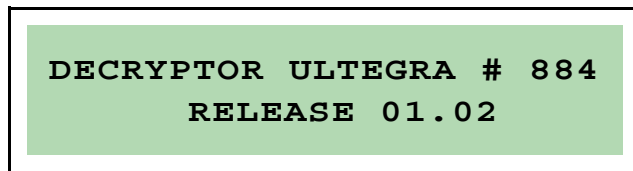

This screen provides information about the type of cloning tool you have and the software version installed in it.



### 6.3.4 TRANSPONDER READING (ON THE ORIGINAL KEY / REMOTE CONTROL)

The main page appears on the screen a few seconds after starting the cloning tool or upon pressing the **"READ"** button. It contains the following message:

INSERT THE KEY  
AND PRESS READ

To read the transponder, insert the key to be "cloned" into the key insertion slot (A)



Confirm the 'reading' instruction by pressing the **"READ"** button:



The following message will appear on the display for a few seconds:

READING IN PROGRESS  
..... PLEASE WAIT .....

Then, in the first line of the display you'll read the following identification data regarding the key transponder:

- Manufacturer (Philips\*, Megamos\*, Temic\*, Texas\*);
- Type;
- Model\* (identified by a code, for instance: PH00).

The second line shows the instruction you need to follow in order to read the key:

```
TRANSP. PHILIPS PH00
PRESS READ
```

\*Philips, Megamos, Temic and Texas Instruments are registered trademarks



---



---

**\*To identify the transponder MODEL refer to table 2 on page 33.**

---



---

If the identified transponder has a "fixed code", press the "**READ**" button to view the code contained in the key transponder.



### CODES: AN EXAMPLE

```
2E13 F724 2080 10E2
E400 0000 0000 8180
```

If the transponder is missing or unknown one of the following messages will appear:

```
NO TRANSP. FOUND
PRESS READ
```

Decryptor Uitegra 884 - Patent pending



UNKNOWN TRANSPONDER  
PRESS READ



---

---

For troubleshooting and solutions refer to paragraph 6.9.0. on page 32.

---

---

After the reading phase is complete, you can remove the key..

#### 6.4.0 CLONING THE FIXED CODE TRANSPONDER

After the Ultegra 884 Decryptor has read and displayed the fixed code transponder code, insert a **KeyLine** read and write-type transponder key and press the **“WRITE”** button:



The following message will appear on the display for a few seconds:

WRITING IN PROGRESS  
.... PLEASE WAIT ....

If writing is successful, the following message will appear:

WRITING SUCCESSFUL  
PRESS READ/WRITE

Press the **“READ”** button to return to the main page; press the **“WRITE”** button and you will proceed with a second cloning, if requested. The following message will appear in case errors occur while the transponder is being written:

WRITING ERROR  
PRESS READ/WRITE



For problem solving hints refer to paragraph 6.9.0. on page 32.

## 6.5.0 CLONING OF KEYS WITH TEXAS\* CRYPTO 1, 2 AND 3 TRANSPONDER (USING THE KEYLINE TK40 ELECTRONIC HEAD)

The main page appears on the screen a few seconds after starting the cloning tool. It contains the following message:

INSERT THE KEY  
AND PRESS READ

1. Insert the original key and press the "**READ**" button



2. The following message will appear on the display for a few seconds:

READING IN PROGRESS  
..... PLEASE WAIT .....

3. If the key identification is displayed on screen as TEXAS® CRYPTO TPXX, it is possible to proceed with the following step:

TEXAS CRYPTO TPXX  
PRESS READ

Decryptor Ultegra 884 - Patent pending



4. You will be asked to program the key. To continue, press "WRITE" again:

```
PROG. CRYPTO KEY?  
RD = NO           WR = YES
```

5. Wait for the processing to end (max. 5 minutes):

```
CALCULATING ...  
PLEASE WAIT           03
```

6. When the calculation is completed, the following message will appear:

```
INSERT TK40  
PRESS WRITE
```

7. Remove the original key and insert the TK40, then press "WRITE" and wait for the end of the process:

```
WRITING IN PROGRESS  
PLEASE WAIT
```

8. If the process is completed successfully, the following message shall be displayed:

```
SUCCESSFUL WRITING  
PRESS READ/WRITE
```

- Press "READ" to go back to the main screen;
- Press "WRITE" to make other copies of the TK40. If you proceed, the writing message shall be displayed again:

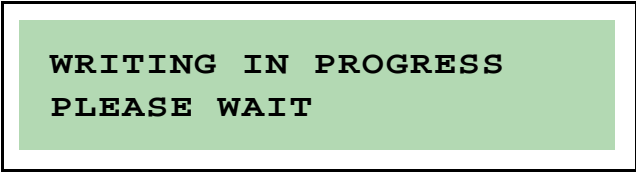

**WRITING IN PROGRESS  
PLEASE WAIT**

The following message will appear in case an error occurs during the key writing:

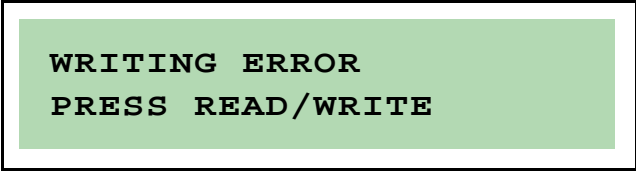

**WRITING ERROR  
PRESS READ/WRITE**

Check the type of key into the reader, press READ to go out or WRITE to start writing again.

## 6.6.0 CLONING OF TRANSPONDER KEYS / REMOTE CONTROLS WITH PHILIPS® CRYPTO PH20 TRANSPONDER (USING TK60)

The main page appears on the screen a few seconds after starting the cloning tool. It shows the following message:

INSERT THE KEY  
AND PRESS READ

1. Insert the original transponder key to be cloned into the 884 "READ-WRITE insertion slot" and press the "READ" button:



2. The following message will appear on the display for a few seconds:

READING IN PROGRESS  
..... PLEASE WAIT .....

3. If the transponder/remote control identification is displayed on screen as PHILIPS® CRYPTO PH20, it is possible to proceed with the following step:

CRYPTO PHILIPS PH20 DETECTED  
PRESS WRITE

4. Leave the original key in the 884 "READ-WRITE insertion slot" and press the "WRITE" button.



Decryptor Ultegra 884 - Patent pending



5. The following message will appear.

INSERT TK60  
PRESS WRITE

6. Pull out the original transponder key, insert the new KEYLINE TK60 and press "WRITE". Wait until the following message appears on the screen:

TK60 STEP 1 COMPLETE  
PROCEED TO STEP 2

7. Assemble the KEYLINE TK60 with the KEYLINE horseshoe used to duplicate the customer's original key blade



- 8. Duplicate the metal section of the original key using the KEYLINE equivalent horse-shoe key.
- 9. Use the TK60 key to turn the car's ignition to the ON position three times (see note).

**Warning:**



---



---

**For Renault cars, during the "8" phase, between one ignition of the electric panel and another using the TK60 key, use the original key to turn the ignition in the ON position. Failing to do so would lead to a blockage of the control unit, which in turn shall require a disconnection of the car's battery for at least 20 minutes.**

---



---

10. Insert the TK60 key into the 884 "READ-WRITE insertion slot" and press "READ".



11. The following message will appear:

**STEP 2 READ COMPLETE  
PRESS READ / WRITE**

12. Press the "WRITE" button.



13. You will be asked to proceed with the programming of the KeyLine key with TK60. to proceed, press "WRITE" again:

**PROG. CRYPTO KEY?  
RD = NO                      WR = YES**

14. Now extract the KeyLine duplicated key, insert the original key as requested and press "WRITE":

**INSERT ORIGINAL KEY  
PRESS WRITE**

15. Wait for the process calculating to end (max. 5 minutes):

**CALCULATING . . .  
PLEASE WAIT                      03**

Decryptor Ultegra 884 - Patent pending

**KEYLINE**  
PASSION FOR KEY INNOVATION



16. When the calculation is completed, the following message will appear:

**INSERT TK60 - STEP 2  
PRESS READ / WRITE**

17. Now pull out the original key, insert the TK60 KeyLine key (used in the previous steps) and press "WRITE". Wait until the following message appears:

**WRITING SUCCESSFUL  
PRESS READ**

18. Now the TK60 KeyLine key is ready for use.

Instructions for cloning of RK60 remote control with PH20 transponder will be available from october 2010.

**CLONING SEQUENCE**



**Decryptor Ultegra 884 - Patent pending**

## 6.7.0 CANCELLATION, IN ORDER TO USE TK60 AGAIN

The TK60 may be reused up to 10 times, the cancellation procedure is as follows:

1. Insert the TK60 into the 884, and press "READ". The following message shall appear:

```
INSERT TK60 - STEP 2
PRESS WRITE
```

2. Press "WRITE" and you will be instructed to proceed with the writing of the key:

```
PROG. CRYPTO KEY?
RD = NO           WR = YES
```

3. Now press "READ" (NO) and the following message shall appear:

```
DELETE KEY?
RD = NO           WR = YES
```

4. Confirm the cancellation by pressing "WRITE" (YES).

## 6.8.0 LANGUAGE SETTING

You can set the language you wish to use following a few easy steps:

1. Turn on the device and press "F1" for two seconds;

The following screen will appear for a few seconds:

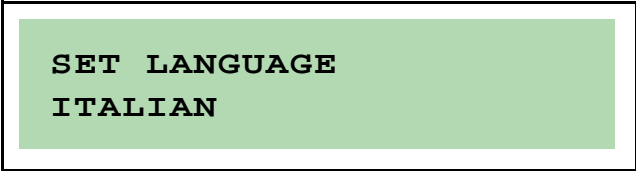

SET LANGUAGE  
ITALIAN

2. Press "READ" to view the languages available in **Ultegra 884 Decryptor**;



3. Once you have selected the language you wish to use (e.g. **ENGLISH**) press the "WRITE" button again;



4. The display will now show the main page in the selected language.

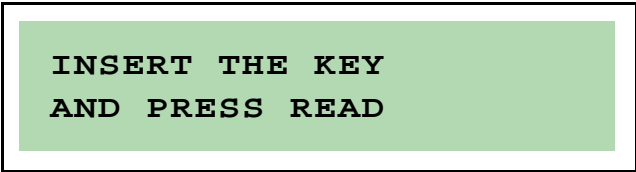

INSERT THE KEY  
AND PRESS READ

**6.9.0 ERROR MESSAGES**

The cloning tool is able to detect problems and anomalies that may occur while the key transponder is being read or written.

The following paragraphs provide a comprehensive list of situations when interruptions could occur and the error messages associated to them.

**6.9.1 ERROR MESSAGES DURING READING**

If problems occur while the transponder is being read, the system will deliver the following error messages.

NR	MESSAGE	MEANING	SOLUTION/CONSEQUENCE
1	NO TRANSPONDER FOUND	The key sample does not contain any transponder or hasn't been inserted properly	Try to read the transponder in a different position
2	TRANSPONDER UNKNOWN	The key transponder has not been identified by the cloning tool	The transponder cannot be identified

**6.9.2 ERROR MESSAGES DURING WRITING**

If problems occur while the transponder is being written, the system will deliver the following error messages.

NR	MESSAGE	MEANING	SOLUTION
1	NO TRANSPONDER DETECTED	The key blank does not contain any transponder or hasn't been inserted properly	Try to write a different key
2	WRITING ERROR	The transponder on the key blank is not compatible with the one required to obtain a duplicate The transponder on the key blank is damaged or it cannot be written properly or it is protected and writing is not allowed	Repeat the writing operation on a different key

**6.10.0 TRANSPONDER IDENTIFICATION**

The cloning tool can identify all the transponder types indicated into the following table.



**Pay attention to the “Philips crypto”: PH10 - PH1A - PH1B - PH1C - PH1D transponders because they work with fixed code and with crypto code too. In this case it is possible to clone only the fixed code but this does not guarantee the car correct functioning.**

**Before cloning these models it is suggested to verify if the car provides fixed code immobilizer system.**





TYPE	ID	DESCRIPTION	SYMBOL
<b>PHILIPS*</b>	PH00	FIXED CODE	
	PH10	CRYPTO	
	PH1A	CRYPTO FOR OPEL	
	PH1B	CRYPTO FOR NISSAN - FORD	
	PH1C	CRYPTO FOR VAG	
	PH1D	CRYPTO FOR PEUGEOT	
	PH20	CRYPTO 2 FOR PSA - FIAT - FORD	
<b>TEMIC*</b>	TM10	FIXED CODE FOR FIAT	
	TM20	FIXED CODE FOR MAZDA	
	TM01	CRYPTO FOR MAZDA	
<b>MEGAMOS*</b>	MG00	FIXED CODE	
	MG10	CRYPTO FOR VAG	
<b>TEXAS*</b>	TX00	FIXED CODE	
	TC01	CRYPTO FOR FORD - NISSAN	
	TC02	CRYPTO	
	TC03	CRYPTO FOR FORD	
	TC04	CRYPTO FOR OPEL - RENAULT SUBARO - HYUNDAI - LINCOLN - CHRYSLER - JEEP - DODGE - EAGLE	
	TC05	CRYPTO FOR FORD	
	TC06	CRYPTO FOR FORD	
	TC07	CRYPTO FOR MITSUBISHI - NISSAN	
TP01	CRYPTO W1 FOR FORD		

Table 2: Transponder table

\*Philips, Megamos, Temic and Texas Instruments are registered trademarks

## 6.11.0 UPDATING THE SOFTWARE

The versatile features of the latest generation's microprocessors allow Ultegra 884 Decryptor to evolve and remain up-to-date.

To update the software you need to connect the **Ultegra 884 Decryptor** cloning tool to a Personal Computer or Notebook.

### PROCEDURE:

1. Load the disk 884 in the computer;
2. Connect the Personal Computer or Notebook to the Ultegra 884 Decryptor by means of an USB cable as shown in figure 5;
3. Go to the "MY COMPUTER" folder of your Personal Computer or Notebook, where the "DISK884" unit shall be displayed;
4. Copy the update file in the "DISK884" unit;
5. The following message shall be displayed:

**UPDATING  
PLEASE WAIT.....**

6. Wait until the device reboots; once the start message is displayed, you can proceed with the normal reading and cloning activities.

**INSERT THE KEY  
AND PRESS READ**



Figura 5: Personal Computer or Notebook connection

The **Ultegra 884 Decryptor** cloning tool is easy to use and well built and does not need any special maintenance.

This chapter contains only some general maintenance instructions.

## 7.1.0 GENERAL INFORMATION

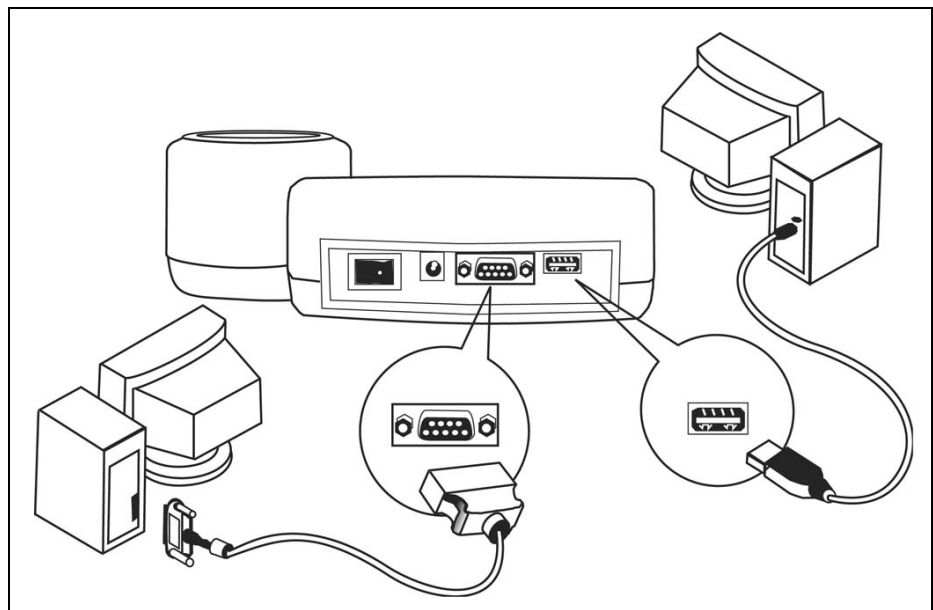
### 7.1.1 SKILLS OF MAINTENANCE PERSONNEL

Maintenance personnel must have specific theoretical and practical skills, that is, they must be qualified.

#### OPERATOR

The machine operator must be knowledgeable about cloning tool operation.

#### PERSONNEL AUTHORIZED BY KEYLINE S.P.A.

Personnel from **KeyLine S.p.A.** Technical Support Service or else officially authorised by **KeyLine S.p.A.** Technical Support Service.



# DISMANTLING AND DISPOSAL

Decryptor Ultegra 884 - Patent pending



## 8.0.1 WASTE DISPOSAL

The disposal of waste generated by the cloning tool shall be managed in compliance with the legislation in force in the user's country. In Europe machine shop rejections are classified as special waste and are assimilated to metal wool when it comes to managing municipal solid waste (MSW).

Such waste must be disposed of according to the legislation in force in the user's country. If machine shop rejections have been contaminated or contain toxic or harmful substances they are considered as toxic -harmful waste and disposed of accordingly in compliance with the legislation in force.

---

---

**The user is responsible for a correct waste management.**

---

---

## 8.0.2 DISPOSAL OF THE PACKING MATERIAL

Our key duplicating machines are delivered in cardboard packages that can be recycled as packing material.

In case of disposal, packing material is treated as municipal solid waste (MSW) and is usually collected together with paper materials. Protective covers are made of polystyrene and must be sent to suitable waste disposal sites as other municipal solid waste of the same type.

## 8.1.0 THE WEEE DIRECTIVE

When disposal becomes necessary, the **Ultegra 884 Decryptor** is to be considered as belonging to the WEEE category (Waste Electrical and Electronic Equipment).

**KeyLine S.p.A.** has always taken great care to protect the environment and complies with the legislative decree on WEEE that has been in force since 13/08/2005. As a consequence, in accordance with the prescriptions of directive 2002/96/CE, this appliance cannot be disposed of as household waste (in compliance with the special symbol shown below).

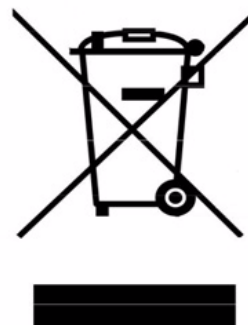



- Whoever disposes of this cloning tool illegally or as household waste will be subject to the sanctions foreseen by current national legislation.
- According to the provisions of current national legislation, this cloning tool cannot be disposed of as household waste. Therefore, at the end of its lifecycle, after having carried out the operations that are necessary for correct disposal, the cloning tool must be taken to one of the differentiated waste collection centres for electrical and electronic waste from domestic households. Refer to the collection centre in your own town, which will guarantee the functionality, accessibility and suitability of the differentiated collection systems, so that the final holder and distributors can take the waste that they produce in their area to collection centres, free of charge.

